

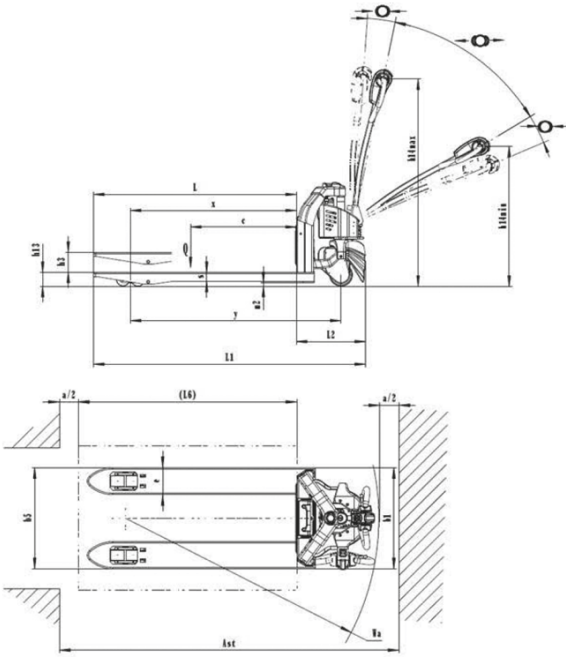

EP 15WS

1.1	Manufacturer		KION BAOLI
1.2	Manufacturer's type designation		EP 15WS
1.3	Drive: electric, diesel, petrol, fuel gas		Electric
1.4	Operator type: hand, pedestrian, standing, seated, order-picker		Pedestrian
1.5	Rated capacity / Rated load	Q (t)	1.5
1.6	Load centre distance	c (mm)	600
1.8	Load distance, centre of drive axle to fork	x (mm)	889/946
1.9	Wheelbase	y (mm)	1261/1205
2.1	Service weight	Kg	195
2.2	Axle loading, laden front/rear	Kg	565/1130
2.3	Axle loading, unladen front/rear	Kg	155/40
3.1	Tyres: solid rubber, superelastic, pneumatic, polyurethane		PU
3.2	Tyre size, front		Ø 210x70
3.3	Tyre size, rear		2x Ø 78x60 (Ø 78x88)
3.4	Additional wheels (dimensions)		-
3.5	Wheels, number front/rear (x = driven wheels)		1x/4 (1x/2)
3.6	Tread, front	b10 (mm)	-
3.7	Tread, rear	b11 (mm)	410 (535)
4.4	Lift	h3 (mm)	115
4.9	Height drawbar in driving position min/max	h14 (mm)	790/1225
4.15	Height, lowered	h13 (mm)	80
4.19	Overall length	l1 (mm)	1638
4.20	Length to face of forks	l2 (mm)	488
4.21	Overall width	b1/b2 (mm)	568 (685)
4.22	Fork dimensions ISO 2331	s/e/l (mm)	50/150/1150
4.25	Distance between fork-arms	b5 (mm)	560 (685)
4.32	Ground clearance, centre of wheelbase	m2 (mm)	30
4.34.1	Aisle width for pallets 1000 x 1200 crossways	Ast (mm)	1739
4.34.2	Aisle width for pallets 800 x 1200 crossways	Ast (mm)	1939
4.35	Turning radius	Wa (mm)	1485
5.1	Travel speed, laden/unladen	km/h	4/4,5
5.2	Lift speed, laden/unladen	m/s	0,029/0,038
5.3	Lowering speed, laden/unladen	m/s	0,046/0,033
5.8	Max gradeability, laden/unladen	%	5/16
5.10	Service brake		Electromagnetic
6.1	Drive motor rating S2 60 min	kW	0.65
6.2	Lift motor rating at S3 15%	kW	0.84
6.3	Battery according to DIN 43531/35/36 A, B, C, no		-
6.4	Battery voltage/nominal capacity K5	V/Ah	2x12/85 24/60 (Li-ion)
6.5	Battery weight	kg	2x22,5 14 (Li-ion)
6.6	Energy consumption according to VDI cycle	kWh/h	-
8.1	Type of drive unit		DC
10.7	Sound pressure level at driver's seat	dB (A)	74

EP 12WS



EP 15WS

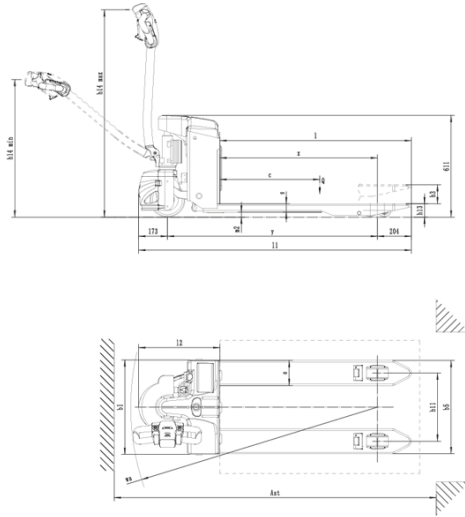

EP 16-N01 EP 20-N04

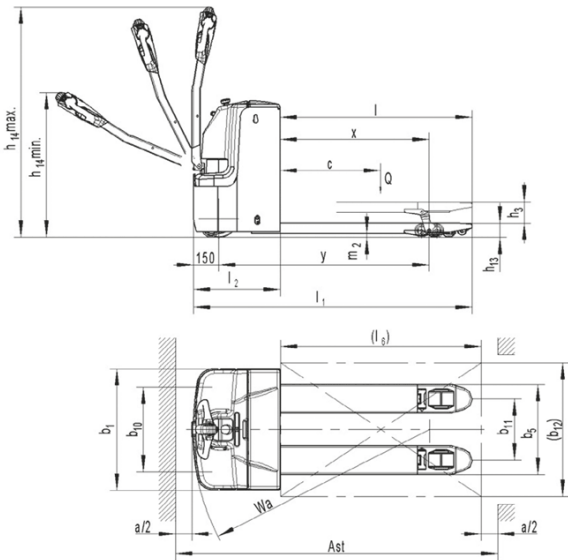

EP 25-N02

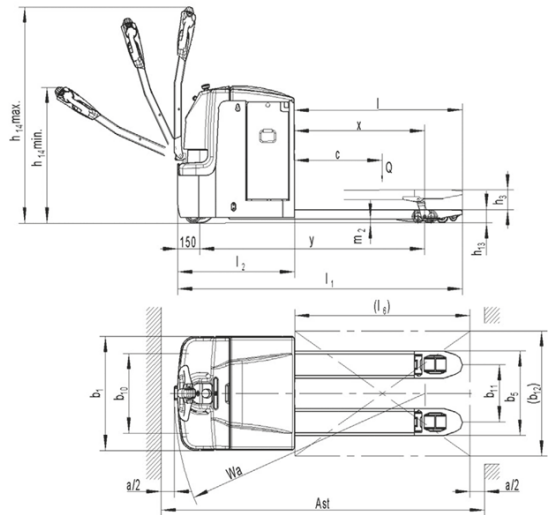

EP 20T

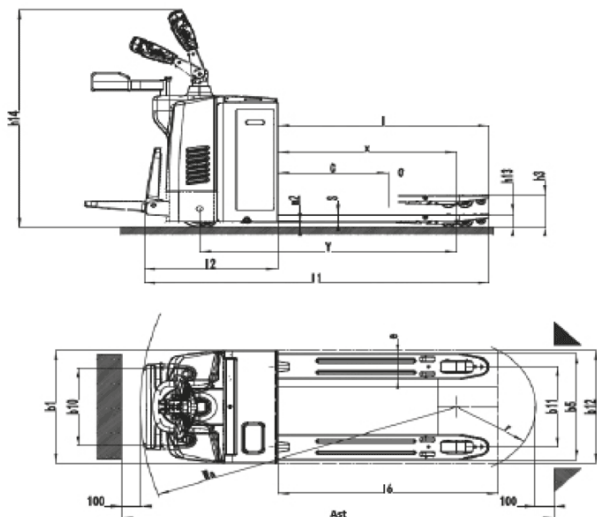

EP 25-N01

